

强力型粉碎机SC系列

SC Series Powerful Granulators

- 特别适用于各类硬性塑胶之粉碎再利用，效果更佳。刀架优化设计，又分为片刀型，爪刀型和平刀型。爪型刀可分散受力度，使得，每片刀的剪切加大，尤其适合厚件产品及大块胶头，硬质料块等，有效的提高了刀具切削力、减少刀具磨损。设有电控安全设计，多项安全保护装置，确保操作安全。
- Strong Granulators are specially designed for crushing various rigid plastics to recycle with high-efficiency. Superior cutter design has 3 types - flake, flat and claw type. Claw cutter has the characteristics of scattering force even to make each blade giving strong shearing force to reduce cutter wear, especially are suitable for hard & thick products cutting. The granulators are specially designed with multiple electricity safety devices to ensure safety protection.



特点 Features

- 活动式筛网，拆装方便，易于清洗换色。
- 爪式刀具，错刀结构，分散冲击载荷，切削效率高。特别适用于尼龙，工程塑胶等又硬又韧之塑料。
- 切割性能好，噪音低。
- 马达附有负荷保护装置，并有电源连锁保护系统，操作，清洗安全
- The movable screen is easy to disassemble, assemble and clean.
- Claw type tool, wrong knife structure, disperse impact load, high cutting efficiency; Especially suitable for hard and tough plastics such as nylon and engineering plastics.
- Good cutting performance, low noise;
- The motor is equipped with an overload protection device and a power supply interlock protection system, which is safe to operate and clean.

参数规格 Specification

型号 Model	粉碎口径 Crushing Chamber	旋转口径 Rotation Diameters	粉碎能力 Crushing Capacity	动刀 Rotary Blade	定刀 Stationary Blade	功率 Motor Power	尺寸 Size	重量 Weight
	MM	MM	Kg/Hr	PCS	PCS	KW/HP	MM	KG
DY-SC180	180*150	Φ150	100~150	9	2	2.2/3	720*460*940	150
DY-SC250	250*220	Φ216	130~200	6	2	4/5.5	900*680*1060	295
DY-SC300	320*240	Φ220	220~300	9	2	5.5/7.5	1020*760*1160	330
DY-SC400	420*275	Φ250	350~500	12	2	7.5/10	1140*900*1310	430
DY-SC500	520*300	Φ260	450~600	15	2	11/15	1260*1060*1450	590
DY-SC600	620*340	Φ300	600~800	18	4	15/20	1600*1260*1685	790
DY-SC700	720*340	Φ300	800~900	21	4	15/20	1600*1260*1685	830
DY-SC800	800*500	Φ400	800~1000	24	4	22/30	2150*1580*2210	1780
DY-SC900	900*550	Φ400	1000~1200	27	4	22/30	2150*1580*2210	1890
DY-SC900	900*550	Φ400	1000~1200	27	4	30/40	2150*1580*2210	1890
DY-SC1000	1020*610	Φ500	1200~1500	30	4	37/50	2350*1760*2580	1950

集中静音破碎机

Soundproof Granulator

特点 Features

- 机身采用全封闭式结构，配备隔音装置，可有效降低粉碎时所产生的噪音；
- 加装电流继电器。马达过载保护及多重安全保护装置；
- 刀具采用SKD-11，强度高，坚固耐用；
- 标配旋风器，可有效分离粉碎料与风，便于原料的收集；
- ≥30HP以上机器箱体标配冷却系统，可有效的降低粉碎室的温度，避免粉碎料融结；
- ≥15HP以上配助力气弹簧，方便投料斗打开，节省人力；
- 可选配带回收除尘装置；
- 标配避震脚，可有效减少粉碎时产生的震动。
- Optimized with full-closed soundproof structure, ensuring the low noise level under operation.
- Equipped with current relay, motor overload protector and other safety devices, to ensure safe operation.
- The cutters are made of SKD-11 featuring wearability and high rigidity.
- Optional part: Sifting device. It can effectively separate the powder and dust and reduce the pollution of recycled materials.
- Machines from 30HP are applied with chamber cooling. It can help reduce the heat caused by friction and avoid material blocking.
- Machines from 15Hp are applied with cylinder for the hopper and screen holder.
- All machine are applied with level pad which can reduce the vibration when operating.

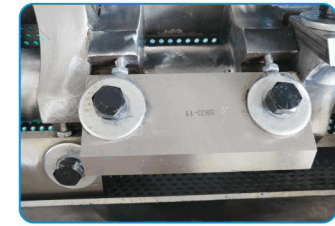
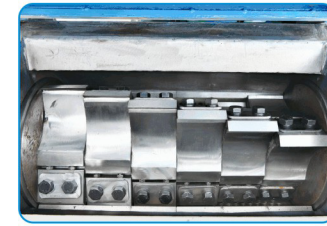

参数规格 Specification

型号 Model	电机功率 Motor Power		爪刀 Claw Blade		片刀 Slice Blade		粉碎能力 Crushing capacity	筛网尺寸 Mesh Size	粉碎口径 Crushing Chamber	净重 Net Weight	尺寸 Size
			定刀 Stationary Cutter	动刀 Rotary Cutter	定刀 Stationary Cutter	动刀 Rotary Cutter					
	KW	HP	PCS	PCS	PCS	PCS	Kg/Hr	MM	MM	KG	MM
DY-SP3	2.2	3	2	9	2	3	100	6	190*160	150	850*500*1100
DY-SP5.5	4	5.5	2	9	2	6	150	8	270*220	220	900*650*1200
DY-SP7.5	5.5	7.5	2	9	2	9	200	8	320*250	300	1000*700*1150
DY-SP10	7.5	10	2	12	2	9	250	8	410*280	400	1100*860*1300
DY-SP15	11	15	2	15	2	9	350	8	500*320	600	1400*1000*1550
DY-SP20	15	20	2	18	2	9	450	10	600*320	1100	1450*1100*1620
DY-SP30	22	30	4	21	4	9	600	10	710*460	1500	1900*1400*1950
DY-SP50	37	50	4	24	4	9	800	12	810*460	1800	2000*1500*2050

慢速破碎机 Low Speed Granulator

特点 Features

- ▶ 慢速塑料破碎机属于无筛网型塑料回收破碎机。低速运转，专门设计用于破碎注塑机产生的各种类型料头、次品的破碎回收利用；
- ▶ 该机具有工作时运转稳定、无噪音、无粉尘污染，而且产品造粒均匀、粉碎效果好，设备运转中无过热现象，使用寿命长等特点。
- ▶ The low speed granulator is designed to regrind the runners from injection molding machines and recycle directly back into IMM. No screen mesh is needed.
- ▶ It's a combination of stability, low noise and low powder. It evenly cuts the material into equal size. The low speed won't lead to overheat and will expand the service life itself.



参数规格 Specification

型号 Model	功率 Power	固定刀	回转刀	旋转刀	转速 Rotating speed	粉碎 Inlet size	粉碎能力 Crushing Capacity	粉碎口 Crushing Chamber	尺寸 Size	重量 Weight
		Fixed Knife	Rotary Knife	Rotary Knife						
单位 Unit	KW	PCS	PCS	PCS	Rpm	MM	Kg/Hr	MM	MM	Kg
DY-LSG220	1.1	6	2	3	23	5~6	15~20	315*248	900*450*1100	205
DY-LSG320	1.5	6	2	3	23	5~6	20~25	315*315	1050*500*1200	275
DY-LSG420	2.2	8	3	4	23	5~6	25~30	410*315	1200*500*1230	315
DY-LSG520	3.7	8	3	4	23	5~6	30~35	440*380	1300*560*1360	480

工作示意图 Working Diagram

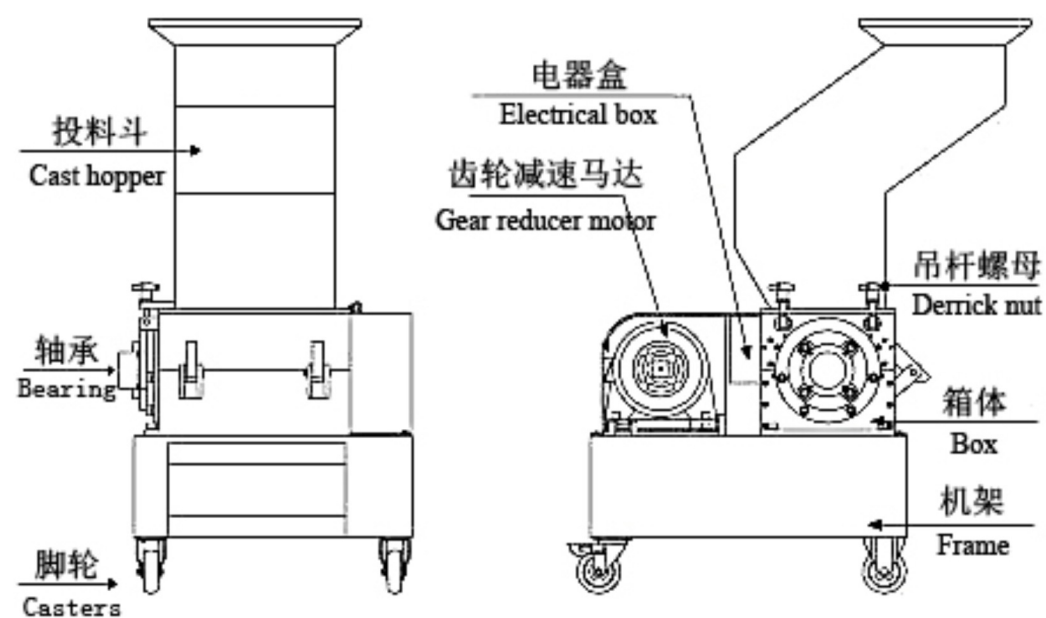

中速破碎机 Medium Speed Granulator

特点 Features

- ▶ 中速破碎机适用于水口料之粉碎再利用，操作简单，性能优异；
- ▶ 采用适中的转速将粉屑、噪音的产生及刀具磨损降到最低点，并且设置多种安全保护装置符合欧洲安全标准，高效安全操作设计；
- ▶ 体积小，占地面积少；
- ▶ 刀架优化设计；
- ▶ 不需任何工具来完成维护，清理；
- ▶ 低粉尘、低噪音、低能耗。
- ▶ Medium speed series granulators are used for recycling runners and easy to operate.
- ▶ The speed is designed to minimize the operating noise and abrasion of the cutter blades. It is adopted with the safety devices meeting the European safety standard.
- ▶ Small footprint.
- ▶ No tools required for maintenance & cleaning up.
- ▶ Less powder caused, lower noise and energy saving.
- ▶ High-grade safety operating,



参数规格 Specification

型号 Model	功率 Power	固定刀	动刀	转子直径	转子宽度	转速 Rotating speed	粉碎能力 Crushing Capacity	粉碎口 Crushing Chamber	尺寸 Size	重量 Weight
		Fixed Knife	Rotary Knife	Rotor Diameter	Rotor Width					
单位 Unit	KW	PCS	PCS	MM	MM	Rpm	Kg/Hr	MM	MM	Kg
DY-MSG200	2.2	8	24	185	335	150	50~100	235*280	800*435*1230	215
DY-MSG300	3.7	10	30	185	395	150	70~150	290*280	900*435*1240	225
DY-MSG5000	3.7	15	45	185	395	150	100~200	430*280	1000*450*1300	255
DY-MSG8000	7.5	11	33	300	600	150	500~600	400*400	1450*900*1600	810

工作示意图 Working Diagram

